

Addressable heat detector AW-D102

AW-D102 heat detector is an intelligent fixed and rate-of-rise temperature heat detector, which can be configured with Addressable Fire Alarm Control Panel.

Each point (device) can be given specific ID, which allows the panel to continuously monitor specific detector location (point).

It works stably and reduces the maintenance cost.



Features

- ✓ Low Standby current for continuous monitoring
- ✓ Two-wire connection
- ✓ Dual LED design provides 360° viewing angle
- ✓ Remote test from Panel

Installation

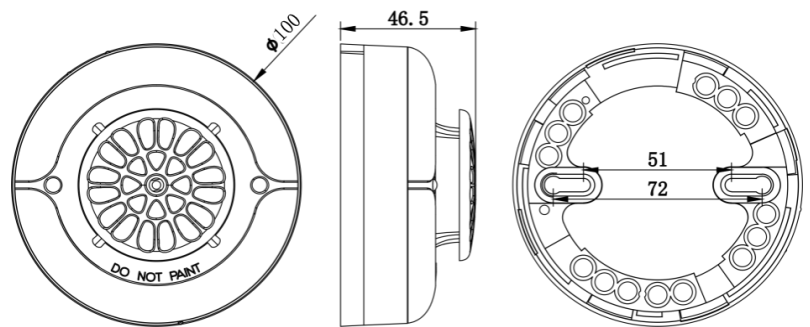

Technical Specification

Model	AW-D102
Operating voltage	18~28VDC @Loop
Operating current(@Loop 24VDC)	Monitoring status≤2.5mA, Alarm status≤3mA
Application	For indoor use only
Wiring	The promise of two bus system(Loop in, Loop out)
Fixed temperature alarm	57°C (135°F) A2R
Rate-of-rise alarm	7.1°C/5s A2R
Environmental	Temperature range: -10~50°C (14~122°F) Humidity: 5 to 95% RH, non-condensing
Materials and colors	ABS, White
Mating host	Asenware fire alarm control panel
Size	φ 100mm* 46.5mm
Weight	About 65g